



Caller ID & Call Monitoring Unit

User Interface Guide
&
Programmer's Reference



WHOZZ CALLING? 2
Caller ID & Call Monitoring Unit

User Interface Guide
&
Programmer's Reference

User Interface Guide Version 3.0 (11/18/03)

Table of Contents

Introduction	1
Requirements and Compatibility	
Computer Requirements	4
Phone Line Compatibility	4
Section I: Users Operating with Software Applications	
Establish Communication Between your Software and the Hardware	6
Connect the Telephone Lines to the Unit	6
Section II: Monitoring the Unit with a Communications Program and	
Programmers Information	7
Establish Communication with the Hardware	7
Setup Toggles, Operating Commands, and Output Format	8
Setup Toggles	9
Operating Commands	10
Memory Commands	10
Set Time Clock Command	10
Detail Mode Output	11
Data Format	11
In-Depth Discussion of Toggles, Commands, and Format	
Setup Toggle Discussion	12
Operating Commands Discussion	13
Set Time Clock Command Discussion	14
Detail Mode Output Discussion	15
Data Format Discussion	
Inbound Calls	16
Outbound Calls	18
Memory Discussion	21
Data Format From Memory	22
Applications	
Typical Applications	
Pop up screens Using Caller ID	24
Simple Call Accounting for Inbound and Outbound Calls	25
Capturing Caller ID Data and Menu Selections in IVR Systems	25
General Application Notes	
Automatic Search for Unit	26
Sending Setup Toggles to Unit	26
Working with the Call Memory	27

Table of Contents (continued)

Section III: Telephone Connections	
4-Wire (RJ14) Phone Cord Connections.....	28
Series or Parallel Connection.....	28
Commercial Installations.....	30
Section IV: Troubleshooting	
Computer Communication Problems.....	33
Loopback Test for a Serial Port Connection in Windows 3.x.....	34
Loopback Test for a Serial Port Connection in Windows 95 later.....	35
Loopback Test Successful.....	36
Capturing Data in a Terminal Program to a Text File.....	36
Telephone Line Problems.....	37
Reconfiguring Unit to Current Detection of On and Off Hook.....	40
Section V: Supplemental Information	
Specifications.....	42
FCC Information.....	42
Manufacture's Information.....	43
Warranty Information.....	43
Appendix A: Voltage vs. Current Detection of On and Off Hook.....	44
Voltage Detection Circuitry and Telephone Lines.....	44
Appendix B: Explanation of Start up Sequence and Front Panel Lights	
Voltage Detection Mode.....	45
Current Detection Mode.....	45
Appendix C: Communication Ports and Interrupts.....	46
Appendix D: RS232 Pin Outs	
9 Pin Connections.....	48
25 Pin Connections.....	48

List of Figures

Fig. 1 - Front and Back Views of 2 Line Model	3
Fig. 2 - Real Time Data Format - Inbound Calls	17
Fig. 3 - Real Time Data Format - Outbound Calls	19
Fig. 4 - Data Format from Memory - Inbound and Outbound Calls	23
Fig. 5a - Connection using a 2 Line Modular Cord	29
Fig. 5b - Connection using 2 Separate Modular Cords	29
Fig. 6 - Series Connection for Commercial Installs	31
Fig. 7 - Parallel Connection for Commercial Installs	32
Fig. 8 - Reconfiguring Unit to Current Detection Mode	41

INTRODUCTION

The unit monitors inbound and outbound phone calls for Caller ID and Touch Tone (DTMF) signals on two telephone lines. Phone call records are sent to a sent via a RS232 serial interface to a computer, terminal unit, or printer. Call records are also written to an on-board memory. The unit does not answer or initiate phone calls. It is compatible with, and does not affect the operation of any telephone equipment attached to the telephone line including telephone switches such as Key Systems or PBX's.

The unit is set from the factory to monitor both incoming and outgoing phone calls. It can be set to monitor only incoming calls. It can send call records immediately after a call begins, just after a call is completed, or both. The unit can also be set to report additional detail information on each call including Ring Signal, Off Hook, On Hook, and Hook Flash.

Up to 248 call records can be stored in non-volatile memory. Call records can be downloaded and erased using simple commands. The memory "rolls over" such that only the last 248 call records are retained.

Setup toggles are case sensitive letters that are stored internally to determine how the unit operates. Upper case (capital) letters turn off options while lower case (small) letters turn on options. Operating commands are available to list the setup toggles, set the time clock, and control the memory.

This manual is divided into 5 sections:

Section I - Users Operating with Software Applications

For users that have purchased a software program designed to interface with this unit

Section II - Monitoring the Unit with a Communications Program and Programmers Information

For a user who simply wants to see the information on screen and log it to a text file
For the software developer that wants programming information and application notes

Section III - Telephone Connections

Advantages of series and parallel connections
Explanation of two-wire (RJ11) and four-wire (RJ14) modular connections
Installations in commercial environments and with telephone switches

Section IV - Troubleshooting

Serial connections problems with the computer
Telephone connections problems

Section V - Supplemental Information

Technical specifications, manufacture's information, and warranty statement

Figure 1 shows the front and back views of the unit. Each channel lights shows the status of the telephone line. The channel light should remain on when the phone line is not in use (On Hook) and should pulse every second when the phone is in use (Off Hook). The channel lights will also follow ring signals and touch tones dialed. The power light will remain on except when the unit is transmitting data.

Power, serial, and telephone jacks are located on the back of the unit. Connect the power supply and serial cable supplied. Telephone lines do not have to be connected in order to establish communication between the unit and the computer (see pages 6 or 7). The two telephone jacks are designed for a 4-wire (RJ14) type modular connection. This means a phone cord that contains 2 active phone lines should be connected. If you are not completely familiar with the above terminology, please refer to "Section III - Telephone Connections" on page 28.

**Do not attach 2 phone cords that carry a different phone lines to each jack.
One of the jacks should be used for an input cord and the other for an output cord.**

Fig. 1 Front and Back Views of 2 Line Model

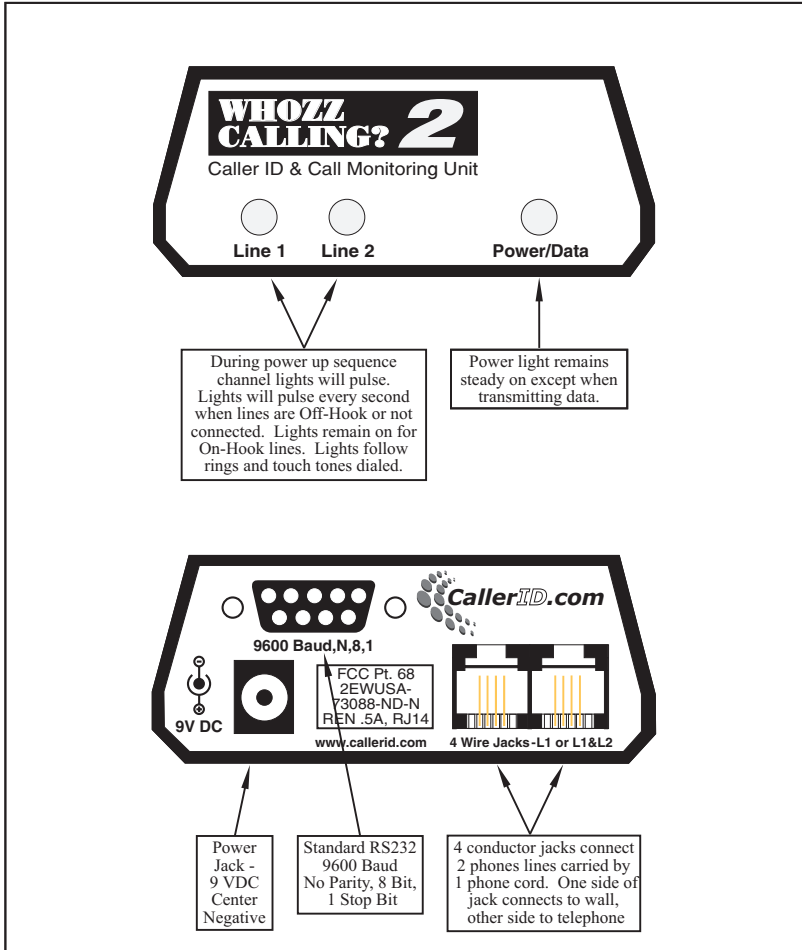

REQUIREMENTS AND COMPATIBILITY

Computer Requirements

The unit must be connected to a dedicated serial port (either 9 or 25 pin) on your computer that is free of COM port and Interrupt (IRQ) conflicts. It is not required that the serial port reside on any particular COM number or IRQ value. This is important only to application software that you may be running in conjunction with the unit. The requirements for computer CPU speed, disk drive space, memory, and operating system are determined by the software application you are running.

Phone Line Compatibility

The unit should be connected to the telephone lines coming into your building commonly know as the Central Office or “CO” lines. These lines are otherwise referred to as flat rate, local loop, or 1FB lines. The unit can also operate on analog Centrex™ lines. If the internal jumpers reconfigured to current detection mode, it can also operate on trunk lines (or “ground start” lines). It will not work connected directly to digital Centrex™, T1, or ISDN lines. If you have an ISDN interface hardware that has analog telephone outputs. outbound monitoring is possible. Also, the unit can monitor outbound calls when placed on analog extensions from a telephone switch. See Table 1 for telephone line type compatibility.

Table 1 - Phone Line Compatibility

Depending on the type of phone line, the unit may be compatible with Caller ID and outbound call monitoring, or just outbound call monitoring only. The unit senses On/Off Hook by detecting the telephone line voltage levels. If the voltage levels are not in standard local loop ranges, the unit can be configured to detect On/Off Hook by means of current flow through the device (see page 40). For additional information on voltage vs. current detection please refer to Appendix A on page 44.

	Caller ID Capture	Outbound Calls	On/Off Hook Detect
Standard Local Loop (1FB)	Yes	Yes	Voltage or Current
Analog Centrex	Yes	Yes	Voltage or Current
Ground Start (Trunk)	Yes	Yes	Current Only
ISDN Interface w/ Analog Ports	Yes, if interface generates <u>analog</u> Caller ID	Yes, through analog ports only	Current Only
Switch Analog Extensions	No	Yes	Current Only
Switch Digital Extensions	Not Compatible	Not Compatible	Not Compatible
ISDN, T1, Digital Centrex	Not Compatible	Not Compatible	Not Compatible

In order to capture Caller ID, an analog Caller ID signal must present on the phone line. This signal can be sent directly from the phone company or certain types of ISDN interface units can regenerate digital Caller ID data as analog Caller ID signals to its analog ports. Analog Caller ID will not pass through telephone switches to extension lines. Even Caller ID compatible telephone switches do not pass or regenerate analog Caller ID signals to extensions lines. This unit will not operate if directly connected to digital phone lines or digital extensions.

SECTION I

USERS OPERATING WITH SOFTWARE APPLICATIONS

This section is provided for users that have purchased a software program designed to run in conjunction with this unit. The first step in getting your complete system functioning properly is to connect the hardware to your computer and run your software program. Only after the software is communicating with the hardware are the telephone connections important. Permanent telephone and computer connections can be made after preliminary testing of the system is accomplished.

Establish Communication Between your Software and the Hardware

The unit connects to a serial port on your computer. Attach the supplied 9 pin serial cable between the unit and a serial port that is not used by any other device. Since serial ports can be either 9 or 25 pins, it may require a 9 to 25-pin adapter that can be purchased at any computer or local Radio Shack store (Catalog # 26-287A).

Connect the Telephone Lines to the Unit

Once your software is communicating with the unit, connect a telephone lines and make a test call. The modular connections on the unit are designed for a 4-wire system (One phone cord carries 2 phone lines). There are two modular jacks on the unit, one jack connects 2 lines coming into the unit from the wall, the other jack connects 2 lines out to your telephone(s). If you are not extremely knowledgeable on telephone wiring please refer to "Section III - Telephone Connections" on page 28 as well as Figs. 5a, 5b, 6, and 7 in the same section showing sample telephone line connections.

NOTE: If you have 2 phone lines and each line is on a separate phone cord, do not connect one cord to each jack. This will cause both phone lines to not work properly.

SECTION II

MONITORING THE UNIT WITH A COMMUNICATIONS PROGRAM AND PROGRAMMERS INFORMATION

Users and programmers that want to communicate directly with and monitor output from the unit can use a modem communications program set up to communicate directly with the serial port. The unit will respond to text commands and deliver text output to the screen. Simple lettered toggle settings determine how the unit operates. Most toggle letters can be set either upper or lower case for use in different applications. The “V” command shows you the present configuration of the unit. The on-board memory is controlled using text commands.

This section provides details on communicating with the unit through a terminal program; discussion on commands and setup toggles; logging information to a text file; data output format; and on-board memory considerations. It also includes unit settings for typical applications and important application notes for software programmers

Establish Communication with the Hardware

The unit connects to a serial port on your computer. Attach the supplied 9 pin serial cable between the unit and a serial port that is not used by any other device. Since serial ports can be either 9 or 25 pins, a 9 to 25 pin adapter may be required and can be purchased at any computer or local Radio Shack store (Catalog # 26-287A). Plug the power supply into the unit.

You can use any modem communications program to establish a connection with the unit. Typical examples are “Procomm”, “Crosstalk”, or “Hyperterminal” for Windows. For detailed instructions on connecting with Windows “Hyperterminal” refer to “Computer Communication Problems” on page 33.

1. Connect power to the unit. The power light should remain on. (At least 1 line light may also be on if a “live” telephone line is connected and is not in use).
2. Launch your communications program.

3. Set up the program to “Direct Connect” to the COMM number of the serial port to which the unit is connected.
4. In the terminal screen, type a capital “V” (Shift-v).
5. The unit should respond: “V1.x ECXUDASoBKT L=01 00/00 00:00:nn”. If it does not respond see “Troubleshooting/Computer Communication Problems” on page 33.
6. Set the units setup toggles: E,C,X,U,D,A,S,O,B,K,T by simply typing the upper or lower case letter required. For an explanation of toggles, see page 9.
7. Connect a phone line to the unit. A discussion of telephone connections is on page 28.
8. Set your program to capture the phone call information to a text file. See page 36.
9. Make test calls and make sure that data is seen on the screen.

Setup Toggles, Operating Commands, and Output Format

When turned on for the first time, all setup toggles are set to their default values. The order of how the toggles are input or displayed is not important. They are stored in non-volatile memory; if the unit loses power, the toggles will remain set. To display the toggle settings at any time use the "V" command. On start-up, the "V" command will display:

Vx.x ECXUDASoBKT L=01 00/00 00:00:nn

Where **Vx.x** is the version number of the master processor firmware, **ECXUDASoBKT** are the setup toggles, **L=01** is the line number of the first channel of the unit, **00/00** is the date, and **00:00:nn** is the time of the internal time clock (in HH:MM:SS).

The default toggle settings below instruct the unit to monitor both inbound and outbound calls and report call records both at the beginning and the end of the call.

ECXUDASoBKT

These toggles can be changed at any time to support various applications such as Call Accounting, Integrated Voice Response (IVR) applications, Pop up screens, and Telephony Diagnostics. Toggles are changed by simply sending the unit the new toggle. In a terminal program, simply type the letter of the toggle (a carriage return <CR> is not necessary). The unit is designed to accept one toggle at a time. If a software application sends an initialization string of toggles to the unit, a short pause of at least 50 msec should be inserted between each toggle so the unit's processor has enough time to write the toggle to memory

Setup Toggles

- E** Echo OFF
e Echo ON **(Not available on the 2 line model)**
- C** \$ sign not sent as leading character in data stream & dashes inserted in phone number.
c \$ sign is sent as leading character in data stream & dashes removed in phone number.
- X** Data format with duration and checksum.
x Limited data format **(Not available on the 2 line model)**
- U** Internal blocking/passing OFF.
u Internal blocking/passing ON
- D** Detail information for call not sent.
d Detail information sent. (Detail information defined below).
- A** Data sent BEFORE and AFTER call.
a Data sent as defined by "S,s" toggle.
- S** Data sent at the Start of call only. (If "a" set above).
s Data sent at the End of call only. (If "a" set above).
- O** Inbound call information sent only.
o Outbound and Inbound information sent.
- B** Block first ring to output jack **(Not available on the 2 line model)**
b Block first ring set to OFF.
- K** Pass all calls
k Block certain calls **(Not available on the 2 line model)**
- T** Do not capture DTMF on inbound calls.
t Capture DTMF on inbound calls. (Used mostly for Voice Mail and IVR applications)

Operating Commands

- @[†] Send back # sign. (Used for establishing device communication).
- V Send firmware Version number, date & time, toggle settings, line numbers.
- R Reset system. Toggles set to default values.

- ? Error (invalid command or could not interpret data)

Memory Commands (see Memory Discussion, page 21)

- ? List number of call records in memory.
- F List all call records in memory.
- \ List last call record.
- > List the next call record.
- < List the previous call record.
- (Dash) Stop listing call records. (Since the memory processor cannot send and receive data simultaneously you may need to press this key a few times to stop listing)
- Y Erase all calls in memory. Type “Y” once to prompt “Erase?” and another “Y” to proceed. Allow approximately 27 seconds to erase memory and return “OK”

Set Time Clock Command

- Zmddhhmm <CR> Set date and time on internal device clock.

[†] Custom versions of firmware may return other characters such as “!” or “+”.

Detail Mode Output

nn R	Date & Time	(24 hour format)	First Ring on line nn
nn F	Date & Time	(24 hour format)	Off Hook on line nn
nn N	Date & Time	(24 hour format)	On Hook on line nn
nn H	Date & Time	(24 hour format)	Hook Flash on line nn
nn Vxx	Date & Time		Firmware version of slave ROM (Displays on start up)

Data Format

The real time data output is similar to the following and shown in Fig. 2, page 17 and Fig. 3, page 19 . For the output format from memory see page 22 and Fig. 4, page 23.

01 I S 0276 G B3 09/26 11:28 AM 800-555-1212 AT&T INFORMATIO <CR/LF>

01	Line number field	2 char.	(preset by user)
I	Inbound/Outbound field	1 char.	(or O for outbound)
S	Start/End of call field	1 char.	(or E for end)
0276	Duration of call in seconds	4 char.	(only sent at end of call)
G	Good checksum for CID string	1 char.	(or B for bad checksum)
B3	Number & Type* of Ring(s)	2 char.	(only sent on end of call)
09/26	Date field	5 char.	
11:28	Time field	5 char.	(12 hour format)
AM	AM/PM field	2 char.	
Phone #	Phone number field	14 char.	(in some cases only 7 digits sent)
Name	Name field	15 char.	(sent only in some areas)

Notes: Each data string is followed by a carriage return and a line feed.
1 space separates each field.

* Type of Ring is valid only if distinctive ring service is ordered from Telephone Company. If distinctive ring service is not present on the phone line, the A,B, or C character reported can be inaccurate.

In-Depth Discussion of Toggles, Commands, and Format

Setup Toggle Discussion

E,e Echo (always off "E" - no Echo option for 2 line model)

C,c Leading \$ character and dashes removed in phone number field

Some applications need to detect a certain character in order to perform an operation. When this toggle is set to **c**, the unit places a \$ character before each data string. This includes detail data strings such as Ring, Off hook, On hook, and Hook flash (see toggle "**D,d**"). Also when **c** is set, the dashes are removed from the telephone number field.

X,x Format Option (always "X" - no format option on 2 line model)

U,u Internal Block/Pass (always "U" - no Block/Pass option on 2 line model)

D,d Detail Information

Some software applications may need additional call data. When the lower case "**d**" toggle is selected, the unit can provide an indication for the first Ring, Off hook, On hook, and Hook flash. The format is as follows: line number (**nn**); space; and either a **R** (**R**ing), **F** (**o**ff hook), **N** (**o**N hook), or **H** (**H**ook flash). The date and time (HH:MM:SS) follow at the same offset as the date/time field in the call record format. In the detail mode, the time is delivered in a 24 hour format. (Please note: If the "**c**" toggle is selected, a leading \$ will be added to the above data string). For more information refer to the Detail Mode Output Discussion on page 15.

A,a Data Delivery Option (Start & End or Start/End)

The unit is capable of delivering a data stream to the host computer immediately when the call starts, when the call ends, or both. For an inbound call, immediate data delivery allows the Caller ID information to be utilized before the call is answered for purposes of popping up screens from database queries, call routing, etc. Delivering the data stream after the call ends provides additional information about the call to the application program such as, the duration of the call and the number of rings before the call was answered. If lower case "**a**" is set, data is sent as defined by the "**S,s**" toggle.

S,s Data Delivery Option (Start/End)

For this toggle to affect operation "a" must be set. If call data is to be sent before the call is answered, set toggle to S. If call data is to be sent only after the call ends, set toggle to s. If call data is to be sent before and after the call set the capital "A" toggle.

O,o Inbound/Outbound Select

For Caller ID only type applications, use the upper case **O**. If complete call accounting is required, use lower case **o**. The lower case **o** instructs the unit to deliver data for both inbound and outbound calls.

B,b First Ring Suppression (always "B" - no first ring suppression on 2 line model)

K,k Block or Pass Select (always "K" - no Block/Pass selection on 2 line model)

T,t Inbound DTMF Monitoring

When set to lower case **t**, the unit will monitor for DTMF touch-tones on inbound calls. This toggle is used primarily for voice mail and Integrated Voice Response (IVR) applications. Any DTMF digits dialed after an inbound call is answered will be displayed in the "Name" field in the call record sent at the end of the call. If the Caller ID service provides the caller's name, the name will still appear in the call record sent at the beginning of the call, but not in the call record sent at the end of the call.

Operating Commands Discussion

@[†] Handshaking character when # is sent

The unit will return "#" when @ is sent. This can be used to establish communication between the computer and the unit. One application for this command is a software setup routine that automatically searches for the unit by sending an @ character on each COM port and IRQ until a "#" is returned. The corresponding COM port and IRQ number then can be set automatically by the application.

V Firmware version and all settings

[†] Custom versions of firmware may return other characters such as "!" or "+".

This command returns the firmware version, all toggle values, line number of the first channel, and date & time (in 24 hour format) on the internal time clock. On start-up the date & time will be set to zero. All toggles are stored in non-volatile memory and will remain saved even if the unit loses power. The internal clock does not run while the unit is off, and therefore, it must be set when power is restored. The clock can be set by the software using the "**Z**" command and will be set on the first good Caller ID signal. Subsequent Caller ID signals with good checksums will continue to reset the internal time clock with the telephone company's time.

R Reset System

This command resets the operating system and resets all toggles to their default values. It does not reset the internal clock. The time clock can be reset by using the "**Zmddhhmm**" command discussed in the next section or by capturing a good Caller ID signal.

Set Time Clock Command Discussion

Zmddhhmm <CR> Set date and time on internal clock

This allows the programmer to set the internal clock on the unit. Since there is no battery backup on board, once power is removed from the unit, the internal clock resets to "00/00 00:00:00". This command may never have to be used, due to the following: On the first incoming call with Caller ID and a good checksum, the internal time clock will be set to the time sent in the Caller ID signal. On every call thereafter, the internal clock is reset to the Caller ID time. The format for time entry using the "**Z**" command is mm (month), dd (day), hh (hour), and mm (minute)

Since the time sent on a Caller ID signal does not include seconds, the internal time clock may differ from by as much as 59 seconds from the last call.

Detail Mode Output Discussion

If the toggle "d" is set, all detail information on each call is sent immediately. The detail events include Ring, On Hook, Off Hook, and Hook Flash. Each event reported by the unit starts with the line number, followed by the abbreviation of the event, and finally, the date and time. The date and time is offset 13 characters to the right so that it will appear in the same offset position as the date and time in the call record format. Also, the time is displayed in a 24 hour format so that the time of the event can be determined exactly, as in example below.

01 R	11/07 07:43:52	First Ring on line 1 at 7:43 (and 52 seconds) AM
01 F	11/07 17:45:04	Off Hook on line 1 at 5:45 (and 45 seconds) PM
02 N	11/07 10:46:23	On Hook on line 2 at 10:46 (and 46 seconds) AM
01 H	11/07 22:11:08	Hook Flash on line 1 at 10:11 (and 11 seconds) PM

Data Format Discussion

INBOUND CALLS

The data string can be, 64 characters in length, including the leading \$ sign (if the "c" toggle is set), spaces, the carriage return, and line feed characters at the end of the data.

The data format for an inbound call is shown in Fig. 2, page 17. The line number always precedes the data string. In this example, data from telephone line 2 is shown.

The Inbound/Outbound and Start/End of Call Indicators use I/O and S/E respectively. Remember that the unit can be set to send data on inbound and outbound calls or only on inbound calls (toggle "O,o"). Also, the data stream can be sent at the start of the call, end of the call, or both (see toggles "A,a" and "S,s").

Since the duration of the call is sent only after the call is complete, toggles "O,o" and "S,s" must be set so the unit will send data at the end of the call. The Caller ID string sent by the telephone company always contains a checksum. The unit compares its checksum with the checksum sent by the phone company and displays either "G" (Good) if they do match or "B" (Bad) if they do not match. The application programmer may elect to ignore this indicator and determine the validity of the data after reading in the data stream.

The next field contains both the number of rings delivered by the telephone company before the call was answered and the type of ring. A service called "Distinctive Ring" or "Ring Master" is offered to customers in many areas. It allows up to 4 telephone numbers to be routed to one phone line. Each phone number dialed causes the telephone to ring differently. The unit will determine which ring pattern is delivered and mark it as A,B,C, or D. Please note the number of rings before answer is always zero except when the data is delivered at the end of an incoming call.

Fig. 2 Real Time Data Format - Inbound Calls

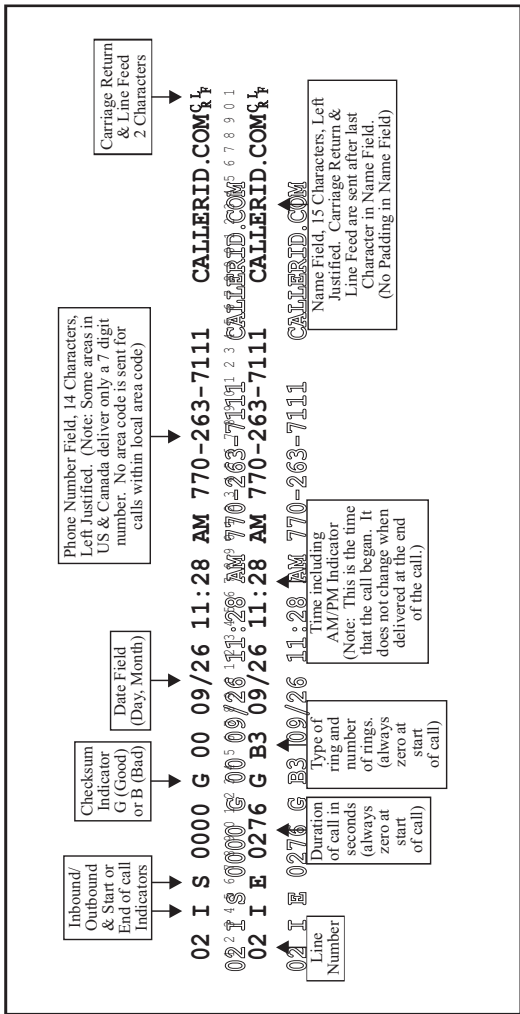

This example shows the format delivered when the upper case "C" toggle is set. The phone number contains dashes and a leading "\$" is not sent.

The date and time information is sent by the phone company as part of the Caller ID signal on each incoming call. For each incoming call with a good checksum, the time and date information will be used to reset the internal real time clock to match the telephone company's clock.

The phone number field is 12 characters and left justified. Dashes are inserted when the "C" toggle is set. If the "c" toggle is set the dashes are removed (and a leading \$ sign is inserted in front of the data string). In some areas of the US and Canada, no area code is sent for calls within the local calling area. In this case, the unit will send the 7-digit phone number, left justified. If the application software will be used in different areas of the country, it is suggested that the local area code reside in the software to be appended to any 7 digit number delivery to make it a 10-digit number.

In many areas, the name of the caller will be delivered along with the number. This service is sometimes referred to as Caller ID Plus, Caller ID Deluxe, or Enhanced Caller ID. If delivered by the local telephone company, the name will reside in a left justified, 15 character field, following the number field. Names for private residences are usually sent last name first, space, first name, space, and then middle initial. Business names are most often sent as they are listed, but if they over 15 characters, truncation will occur. Even though most local telephone companies send all upper case names, the Bellcore and Bell Canada specification provides for the delivery of both upper and lower case characters.

OUTBOUND CALLS

Figure 3 on page 19 shows the data format for outbound calls. Unlike Fig. 2 on page 17, toggle "c" is set. (Remember toggle "c" places a \$ sign before the data stream and removes dashes in the phone number field.)

The outbound indicator displays **O** and the Start/End indicators are the same as inbound calls. The duration of the call is only sent at the end of the call and is displayed in seconds. The checksum indicator is always "good" and the number of rings remains "zero" at all times. The date/time displayed is the date/time that the call was initiated and does not change at the end of the call.

Fig. 3 Real Time Data Format - Outbound Calls

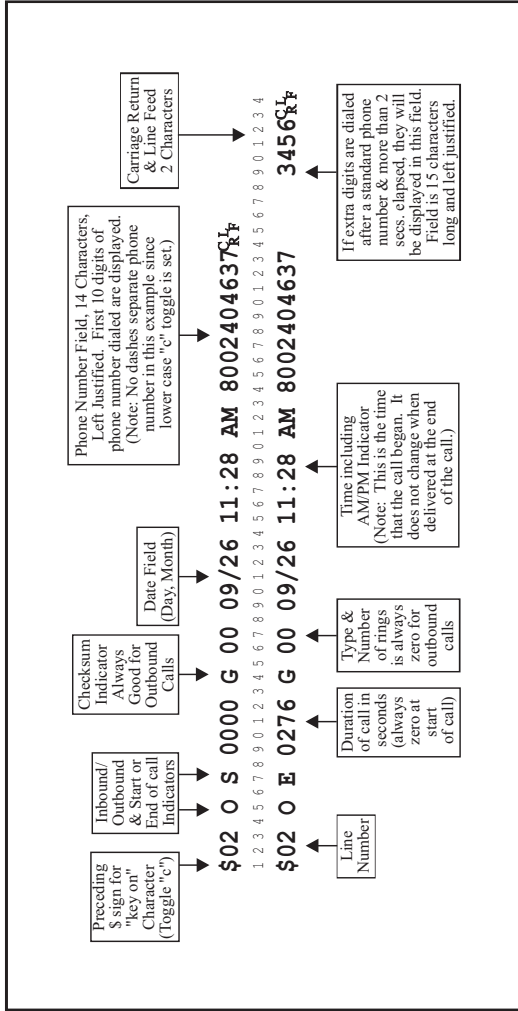

This example shows the format delivered when the lower case "c" toggle is set. A leading "\$" is sent and the dashes are removed from the phone number.

Dialed digits are placed in either the number or name field. The algorithm below explains that unit tries to be as "smart" as possible in determining where to place outbound dialed digits. The unit places all digits dialed within 2 seconds of each other beginning in the number field. If more than 10 digits are dialed, the additional digits will be displayed in the name field. The "start" data string for outbound calls will be sent immediately after a period of 2 seconds when no digits are dialed. Any digits dialed after this 2-second interval will be displayed in the name field and will be displayed only at the end of the call. For example the second data string shown in Fig. 3, the 800 number was originally dialed and after a few rings, an automated answering device answered the call. The caller then dialed additional digits responding to voice menu selections.

An exception to this second rule provides for 7 and 10 digit numbers to be reported in the number field on the end record, regardless of the interval between dialed digits.

Memory Discussion

The unit contains a non-volatile memory that does not use a battery. Call records in memory will be retained even for indefinite power outages. The unit must have power in order to write new call records. A record is written to memory for each phone call made regardless of whether that information was recorded by the monitoring computer.

The memory stores a maximum of 248 call records. Once this is exceeded, the most recent call record is added to the end of the memory while the oldest call record is removed. In other words, only the last 248 calls are stored. The unit contains no warning mechanism to alert the user that the memory is full.

Only “End of call” records are written to memory. Even if the unit is set to deliver only “Start of call” records to the computer, the “End of call” record will be still written to memory. Refer to page 8 and page 12 for a discussion on setup toggles for “Start” and “End of Call” records.

The following memory commands are the same as listed on page 10.

- ? List number of calls records in memory.
- F List all call records in memory.
- \ List last call record.
- > List the next call record.
- < List the previous call record.
- (Dash) Stop listing call records. (Since the memory processor cannot send and receive data simultaneously you may need to press this key a few times to stop listing)
- Y Erase all calls in memory. Type “Y” once to prompt “Erase?” and another “Y” to proceed. Allow approximately 27 seconds to erase memory and return “OK”

DATA FORMAT FROM MEMORY

The output format from memory is slightly different than from the real time output. Each memory record is preceded by the record number and fields in the record are rearranged.

Compare the real time data format on page 16 also shown in Fig. 2, page 17 and Fig. 3, page 19 with the example output format from memory below and also shown in Fig. 4, page 23.

0248 02 09/26 13:28 I E 0276 G A3 800-555-1212 AT&T INFORMATIO <CR/LF>

- | | | | | |
|---|--------------|-----------------------------|----------|----------------------------------|
| * | 0248 | Call record number | 4 char. | (first call is 0001) |
| | 02 | Line number field | 2 char. | |
| * | 09/26 | Date field | 5 char. | |
| * | 13:28 | Time field | 5 char. | (24 hour format) |
| | I | Inbound/Outbound field | 1 char. | (or O for outbound) |
| | E | Start/End of call field | 1 char. | (always E for end record) |
| | 0276 | Duration of call in seconds | 4 char. | (only sent at end of call) |
| | G | Good checksum on CID | 1 char. | (or B for bad checksum) |
| | A3 | Number of & type of ring(s) | 2 char. | (only sent on end of call) |
| | Phone # | Phone number field | 12 char. | (some areas only 7 digits sent) |
| | Name | Name field | 15 char. | (not sent in some areas) |
- * Notice that the Time and Date fields have been moved to the left after the record number and line number. This is conducive to quick visual scanning.

Note: Each data string is followed by a carriage return and a line feed. Fields separated by 1 space.

Fig. 4 Data Format from Memory - Inbound and Outbound Calls

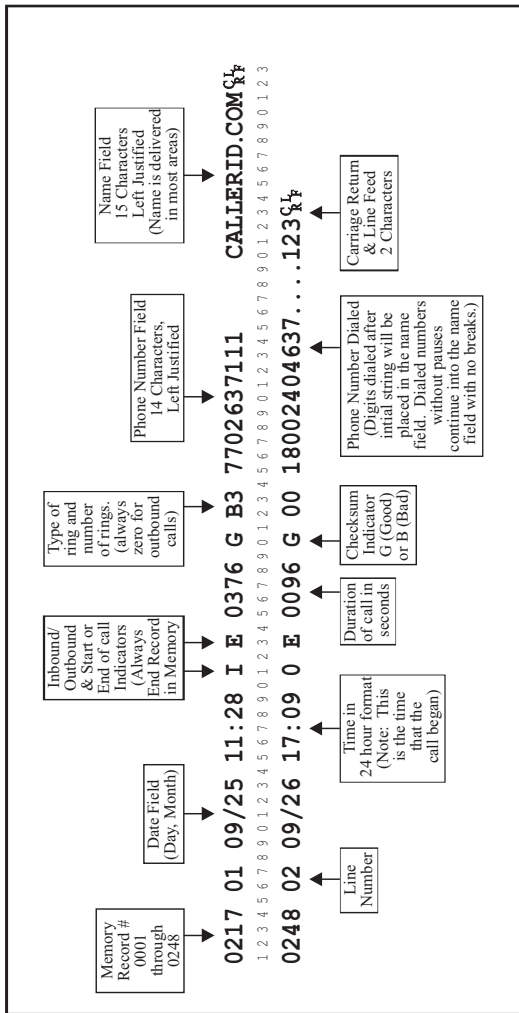

The format from the memory is always as shown below. The "C,c" toggle does not affect this format. Regardless of how the "A,a" and "S,s" toggles are set, only the "End Record" is written to memory.

Applications

Typical Applications

POP UP SCREENS USING CALLER ID

A typical Caller ID application involves performing a database query based on a Caller ID number. When the database record is found, the customer's record is presented on the user's screen. The data from the unit is read from the serial port, the Caller ID number is extracted, and a database query is performed.

Since the unit is designed to always send Caller ID information no setup toggles have to be defined. If you do not want to monitor outbound calls, you must set the upper case "O" toggle. Also, detailed information (On Hook, Off Hook, and Ring) can be sent by the unit by setting the lower case "d" toggle. The unit can also send an "end of call" record that includes call duration and number of rings before answer. If this information is not required, set the lower case "a" and upper case "S" toggle.

The Caller ID number, by definition, is the phone number of the specific phone line used to originate the call. Many businesses have more than one phone line with each having a separate number. You should make provisions in your software application to look up the same database record for multiple Caller ID numbers. This is typically accomplished by using a cross-reference list for each database record. A new Caller ID number from an existing customer can be added to the cross-reference list by the employee answering the call. Eventually, all numbers from a particular customer will be cross-referenced to the main database record.

This cross-reference list can also be built automatically from the Caller ID name information. Fortunately, the Caller ID name generated by the phone company is based on billing records and spelled the same no matter which phone line is used to originate the call. Therefore, if the Caller ID name is contained in the database, the cross-reference list can be appended automatically.

The employee using the software will want some manual control popping up new database records. An example is an order taker adding notes to a customer's record after a call is completed. Manual control prevents a new call from changing the screen before they are finished. One method to accomplish this is to display the Caller ID name and number on a small window in the corner of the screen and allow the user to choose when to pop up the new record.

SIMPLE CALL ACCOUNTING FOR INBOUND AND OUTBOUND CALLS

When only call logging is required and reporting will be performed afterwards, the unit can be set to report only "end of call" records (lower case "a" and "s" toggle set). The information reported in the end record contains the same information as the start record and but adds the call duration and the number of rings before answer.

The only instance when the above statement is not true is when the lower case "t" toggle is set. Lower case "t" instructs the unit to capture touch-tones digits after an inbound call has been answered. These digits are placed in the Caller ID name field on the "end of call" record and substitute for the Caller ID name. If your application requires that the Caller ID number, Caller ID name, and inbound touch tones are reported, then the unit must be set to report both "start of call" and "end of call" records. This would require the upper case "A" toggle to be set.

CAPTURING CALLER ID DATA AND MENU SELECTIONS IN IVR SYSTEMS

A typical example of this type of application is in the real estate industry. Agents record details for listed properties on a system where potential clients can call in to find out more information. These callers maneuver through voice menus using touch-tones to listen to specifics on various properties. By capturing the Caller ID number, Caller ID name, and the menu choices, the agent can turn potential clients into sales leads.

For this type of application, the unit needs to set to capture "start of call" and "end of call" records as well as touch tones pressed after the call is answered. Set the upper case "A" and the lower case "t" toggles. Both the "start of call" and "end of call" records must be captured when the Caller ID name and touch tone digits dialed are required. These digits are placed in the Caller ID name field on the "end of call" record and substitute for the Caller ID name.

Usually this application does not require monitoring outbound calls, so the upper case "O" toggle would be set.

General Application Notes

AUTOMATIC SEARCH FOR UNIT

The user of your software application may not know the COMM port number or Interrupt (IRQ) value of the serial port in which the unit is connected. We recommend a search routine that tries different combinations of COMM port numbers and IRQ values to find the unit. For each combination your software should send an "@" symbol; the unit will respond with a "#" symbol. This automatic search will help minimize serial communication support. To further help with initial computer connections, you might consider a quick link to a simple terminal program preset at the correct serial parameters (9600, N, 8, 1).

SENDING SETUP TOGGLES TO UNIT

A design limitation of the unit is that it can only send or receive data at one instant. Therefore, the unit must be idle when your application sends setup toggles. Also, the master processor of the unit must have enough time to read a toggle and write it to memory before it can receive another. Your application software must allow at least 50 milliseconds between toggles being sent.

Setup toggles are stored in non-volatile memory. The master processor retrieves these toggles and sends them to the 2 slaves processors during the power-up sequence. When toggles are changed by the application software after power-up, the slaves will receive these changes only when they request the toggle status. Slaves request the toggle status during extended periods of inactivity. Depending on the processor cycle time a change in a toggle after power-up may take as long as 2 minutes for the slave to recognize it. Fortunately, this should be an inconvenience only when the application initializes unit for the first time since setup toggles rarely change for a particular application.

WORKING WITH THE CALL MEMORY

The unit writes call records to both the serial port and to memory. The memory may become full even when it is connected to your application. The memory will scroll, so only the latest 248 calls will be in memory at any time. We recommend that when a user gracefully exits from your application, a software routine erases the memory. In the interest of exit time, it may not be necessary that your program wait for the unit to return "OK".

The memory is erased using the "Y" command twice (see pages 10 and 21). The memory requires approximate 27 seconds to erase no matter how many of call records are stored. With the exception of erasing upon a graceful exit, it is best if your application simply waits until an "OK" is sent to continue.

The unit can store 248 calls in memory. Beyond this limit, the memory scrolls dropping the oldest call and adding the newest as the 248th call. While call records are downloading from memory, real-time call records cannot be sent from the unit. If a call happens to arrive while the unit is downloading, the call record is stored in the slave processor. It will be sent to the application once the download through the master processor is complete.

You may consider using the "?" command to inform the user how many calls are in memory before downloading. The user may then have a choice to download immediately or wait. It takes approximately 35 seconds to download the entire memory. If you allow the user to stop the download before is completed, your application must send a "-" (dash) character to the unit. Since the processor can only read or write at one instant, it only looks for the dash command between records sent. You will have to send the dash between downloaded records.

Depending on when the memory was last erased (which may depend on whether a graceful exit was performed by the user) some records in memory may be duplicates of phone calls captured in real-time. It is highly recommended that a routine be incorporated to eliminate duplicate call records in your log files.

In order to save memory space, only end records are written to memory. This fact prevents storing both Caller ID names and digits dialed after an inbound call is answered (lower case "t" toggle) in the memory (see pages 9 and 12). Also, if the unit is set to deliver only "start of call" records in real-time, the memory will still log "end of call" records.

SECTION III

TELEPHONE CONNECTIONS

4-Wire (RJ14) Phone Cord Connections

Most modular phone cords contain 4 wires that can carry two phone lines (2 wires for each line.) Your system may have either 2 of the wires connected (RJ11 - 1 phone line) or four wires connected (RJ14 - 2 phone lines). The modular connectors on the unit are equipped to handle 4-wire RJ14 connections. If you have a 4-wire system refer to Fig. 1a for connections.

A 2-wire, RJ11 system can be converted to 4-wire, RJ14 system in a number of ways. Check with your telephone vendor or local Radio Shack™ store for available adapters. A modular adapter to make this conversion sold by Radio Shack is catalog # 279-402. Please note that a simple modular duplicator (Radio Shack #279-357) will not work. Figure 2b diagrams a 2-wire to 4-wire conversion and connection to the unit.

Series or Parallel Connection

A series phone line connection uses both modular jacks on the unit. A phone cord connects from the wall into one of the jacks and another cord connects the other jack to the telephone and other telephone equipment (similar to Fig 2a). A series connection is preferred since the unit will operate properly whether it remains configured to the factory default voltage detection mode, or it has been reconfigured to the current detection mode. For an explanation on how to accomplish this, see page 40. Additional information on voltage vs. current detection of On and Off Hook can be found in Appendix A on page 44.

A parallel phone line connection uses only one of the modular jacks. The wall outlet is split such that one cord connects to the unit, and another cord connects with the telephone and other telephone equipment. This type of connection can be used only if the unit remains configured in the factory default voltage detection mode. Current detection will be used only if the voltage Detection is not compatible with your phone lines as explained in “Section IV - Trouble-shooting” on page 37. Additional information on voltage vs. current detection of On and Off Hook can be found in Appendix A on page 44.

Figure 5a - Connection using a 2 Line Modular Cord

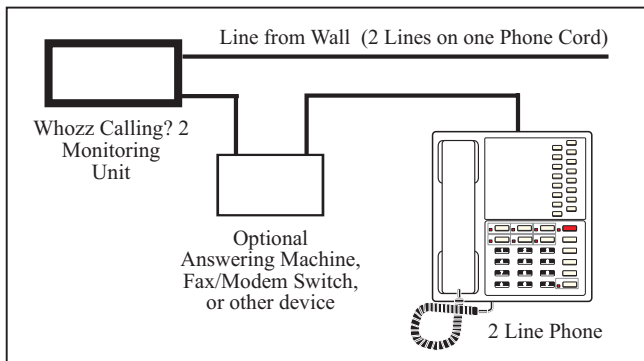
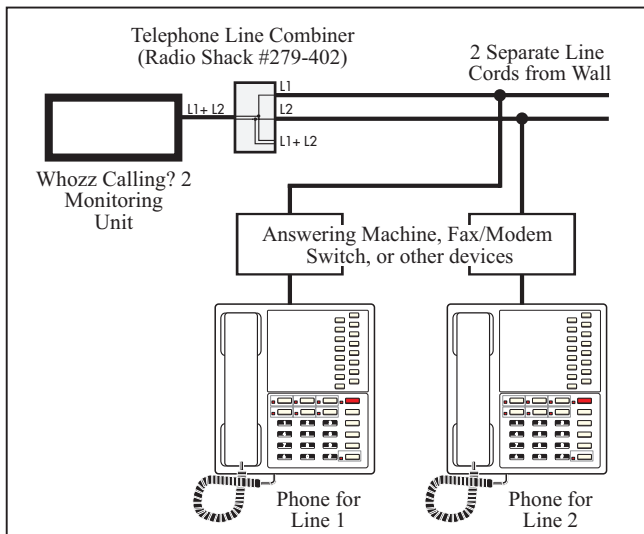

Figure 5b - Connection using 2 Separate Modular Cords



Commercial Installations

If the unit is to be attached to the telephone company's termination point (De-mark) then refer to Figs 6 and 7 below. The diagrams show wiring coming into the building consisting of pairs of solid wire attached to a punch down block. A series (pass through) connection is recommended since the unit will operate properly even if it has to be reconfigured to a current detection mode (see page 40). But in many cases, a parallel (tap, half-tap, split, or tee) connection is easier and will suffice.

When a telephone switch (Key Switch, PBX) is on-site, make sure that the unit is wired "in-front" of the switch (i.e. between the De-mark and the switch). The unit will not capture Caller ID data if connected to switched extension lines. Refer to page 4 for compatibility with different type of phone lines.

Fig. 6 Series Connection for Commercial Installs

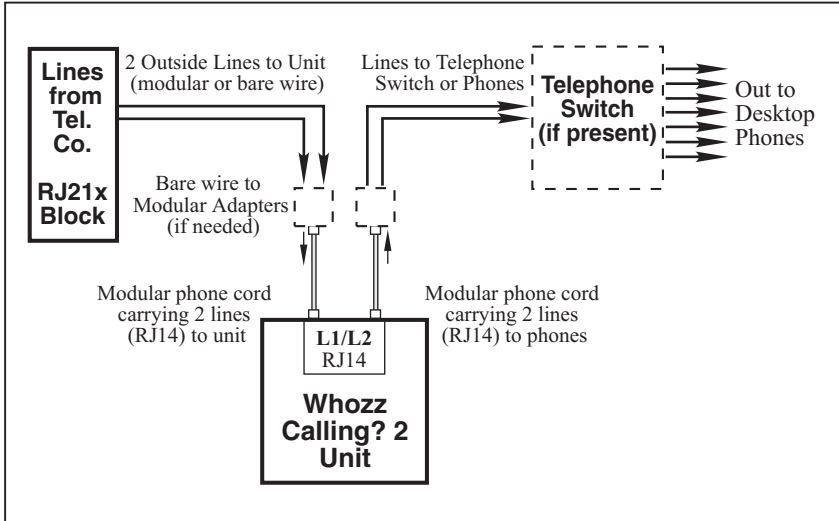

Lines coming into the building from the telephone company are connected to the input jacks on the monitoring unit. If these lines do not terminate in modular connectors, solid wire to modular adapters need to be installed. The output lines from the unit go to the desktop phones. If a telephone switch is present, they connect through the switch first. A series connection is necessary only if the unit has been set to current detection mode via internal jumpers.

Fig. 7 Parallel Connection for Commercial Installs

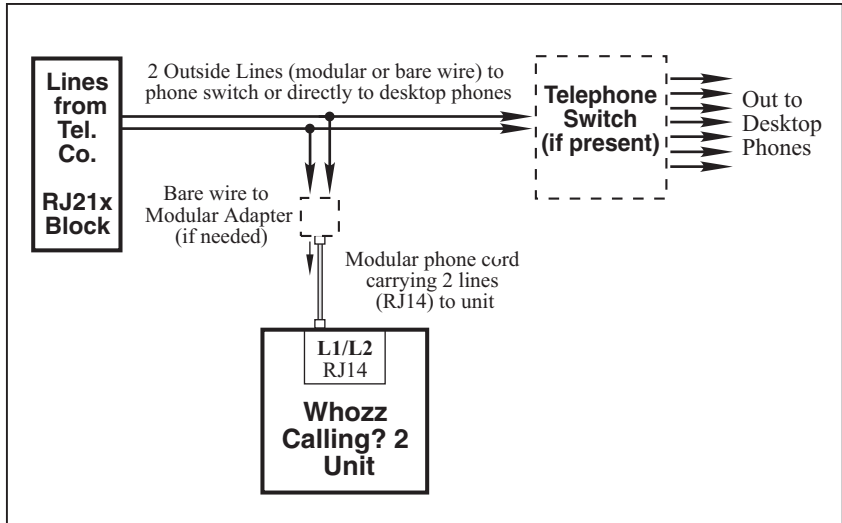

Lines coming into the building from the telephone company are connected to the telephone switch or directly to desktop phones. These lines are branched (or tapped) so that they can be connected to one jack of the monitoring unit. If these lines are not modular, solid wire to modular adapters need to be installed. A parallel connection can be used only if the unit is configured to its factory default voltage detection mode.

SECTION IV

TROUBLESHOOTING

Computer Communication Problems

I - Symptoms:

- ▶ I do not see any call data on my screen in my application software.
- ▶ My application software says it is not communicating with the hardware.
- ▶ I cannot see call data in terminal mode.

I - Assumptions:

- ▶ Telephone lines are connected correctly
- ▶ The unit is connected to a serial port
- ▶ Power is connected to the unit.

I - Problems:

- ▶ The software is not configured to the correct COMM port number on which the serial port resides.
- ▶ The serial port that the unit is connected to has a COMM port or Interrupt (IRQ) conflict.

I - Solutions:

Determine which communication (COMM) port number the serial port is configured to and whether it has a COMM port number, or Interrupt (IRQ) number conflict with an internal modem or other device. For more on COMM ports and IRQs see Appendix C, page 46.

To determine whether the serial port is configured and working properly use any modem communications program such as “Hyperterminal” in Windows, and follow the Loopback test procedure below.

Loopback Test for a Serial Port Connection in Windows 3.x

1. Make sure that any software program that runs in conjunction with Whozz Calling? is closed.
2. Run **Terminal** from the Accessories Program Group.
3. Select **Settings/Communications**
4. Set **Connector** for the desired COM port.
5. Set **Baud Rate: 9600, Data Bits: 8, Stop Bits: 1, Parity: None, Flow Control: None**
6. Select **Settings/Terminal Preferences** and set **Local Echo to OFF**
7. Disconnect the serial cable from the unit, and attach the supplied Loopback Connector to the cable (the other end is connected to the serial port on the PC).
8. Type any character.
 - a. If the character you typed shows on the screen, the serial port is functioning properly, the test is positive.
 - b. If you do not see the character typed, select **Settings/Communications**, select another COM port and repeat steps 3-8.

NOTE: If a fax/modem board is installed in your computer, the Loopback test performed on this COM port will give a false positive result. You can check to see if the FAX/modem is on the COM port your testing by typing "AT" and pressing the "Enter" key. A FAX/modem will return "OK".

9. If you obtain a positive result, skip to "Loopback Test Successful" on page 36. If not, you may have a conflict between your serial port settings and an internal device such as a FAX/modem. Consult your computer technician to resolve the conflict.

Loopback Test for a Serial Port Connection in Windows 95 or later

1. Make sure that any software program that runs in conjunction with Whozz Calling? is closed.
2. Run **Hyperterminal** from the Accessories Program Group.
3. In the Connection Description dialog box Type: “**Test**” on the Name line and Select: **OK**
4. In the Phone Number dialog box leave phone number blank and Select: Connect using Direct to COMx. Where “x” represents the COM port number being tested (ex. 1,2,3, etc.) Select: **OK**
5. In the Properties dialog box Select Bits per second: 9600, Data bits: 8, Parity: None, Stop bits: 1, and Flow Control: None. Then Select: **OK**
6. Select: **File/Properties**. In the Test Properties dialog box select the **Settings** tab and set Emulation to **ANSI**. Select **ASCII Setup** and make sure that Echo typed characters locally box is not checked. Select: **OK** to close and **OK** again to close the Test Properties box.
7. Disconnect the serial cable from the unit, and attach the Loopback Connector to the to the cable (the other end is connected to the serial port on the PC).
8. Type any character.
 - a. If the character you typed shows on the screen, the serial port is functioning properly, the test is positive.
 - b. If you do not see the character typed, Select: **Call/Disconnect**. Select **File/Properties**, choose another COM port and click **OK**.
 - c. Select: **Call/Connect** and type any character again and repeat above as necessary.

- NOTE:** If a fax/modem board is installed in your computer, the Loopback test performed on this COM port will give a false positive result. You can check to see if the FAX/modem is on the COM port your testing by typing “AT” and pressing the “Enter” key. A FAX/modem will return “OK”.
9. If you obtain a positive result, skip to “Loopback Test Successful” on page 36. If not, you may have a conflict between your serial port settings and an internal device such as a FAX/modem. Consult your computer technician to resolve the conflict.

Loopback Test Successful

After a successful Loopback test, reconnect the unit and type a capital “V” (Shift “V”). The unit will respond with the firmware version number, setup toggles, line number of the first channel, and date & time. The unit is now communicating with the serial port. Note the COMM port number to which you are directly connected.

Make a test phone call on each of the phone lines. If the phone call data appears on your screen, most likely the phone lines are connected correctly and the unit is working properly. If you are using application software, exit your terminal program and run your application software again. If phone call data still does not appear in you application software, determine whether the software can be manually configured to the correct COMM port. Contact your application software provider if problems still persist.

Capturing Data in a Terminal Program to a Text File

Monitoring the output from the unit in a terminal program does not save data unless you capture it to a text file. If not captured, the data that scrolls off your screen is lost. When you enter your terminal program you must immediately set it to capture data to a file. Since terminal programs can be set to append data to an existing text file, you can capture data to the same file every time you run your terminal program. Below are instructions on how to start capturing data to a text file for three specific terminal programs. If you are using another terminal program refer to its help instructions.

From the terminal screen:

Procomm Plus for DOS - Press Alt-F1, type text file name

Window 3.x Terminal - Select: Transfers/Receive Text File, and type text file name

Windows 95, 98 Hyperterminal - Select: Transfer/Capture Text, and type text file name

Telephone Line Problems

I - Symptom:

- ▶ One or more telephone lines are “dead” or not working properly when connected to unit.

I - Assumptions:

- ▶ Telephone lines worked correctly before connecting to the unit.
- ▶ Telephone line cords are good.

I - Problems:

- ▶ If both lines connected to the unit are “dead”, the two phone lines are connected together “shorting out” both lines.
- ▶ If only one line of two is “dead”, that line is not connecting through the unit.

I - Solutions:

- ▶ Do not make the mistake of connecting phone Line 1 into one side of the unit’s jack and phone Line 2 into the other side of the unit’s jack. This will “short out” both lines.
- ▶ Check your connection carefully referring to either Fig 5a and 5b on page 29.
- ▶ You must completely understand 2 wire and 4 wire telephone cords, see page 28.

II - Symptoms:

- ▶ The unit does not report outbound calls.
- ▶ The unit reports the duration of phone calls longer than the actual duration.
- ▶ The unit reports a phone line being hung up (On hook) only when the next incoming call is received.

II - Assumptions:

- ▶ The unit is set to monitor outbound calls (set by application program or lower case “o” when viewing from a terminal program).
- ▶ Phone being used to make calls is set to touch tone dialing.
- ▶ Unit is connected to standard analog phone line or analog phone switch extension (not digital lines). Refer to “Phone Line Compatibility” on page 4 for more information.

II - Problems:

- ▶ a) Chances are the unit is not detecting On Hook and Off Hook properly. Check to see if the line lights on the front panel of the unit remain on when the phone is not in use (On Hook).
- ▶ b) If **a** is seems ok, check whether the line light on the front panel of the unit goes off and blinks once every second when you pick up the handset on that line (Off Hook).
- ▶ c) If **a** and **b** seen ok, pickup the phone handset and dial digits 0 through 9 and check whether the line light comes on during each digit dialed.

II - Solutions:

- ▶ a) If the line light(s) does not remain on when the phone is in use, you must reconfigure the unit to detect On Hook and Off Hook by using current detection (instead of the factory default voltage detection).

This is accomplished by opening the unit and moving jumpers on the circuit board. See below for specific instructions for reconfiguring the unit to current detection of On and Off Hook, and refer to Fig. 8, page 41. For more information on Voltage vs. Current Detection of On and Off Hook refer to Appendix A, page 44.

- ▶ b) If **a)** seems ok, and **b)** seems to be the problem, carefully check your telephone connections. Also try going Off Hook with another phone and check the lights.
- ▶ c) If **a)** and **b)** seem ok, and c) seems to be a problem carefully check your telephone connections. Try going Off Hook and dialing digits with another phone, and check the lights. Also, try replacing the batteries in your telephone. When the batteries in some telephones are low, the touch-tones generated are weak.

Reconfiguring Unit to Current Detection of On and Off Hook

If the unit does not correctly detect your phone(s) going On and Off Hook, the voltage levels on your phone line(s) are out of standard range. Your telephone company will not address this issue. The solution is to reconfigure your unit to detect On and Off Hook via current flow through the device.

Unfortunately, once reconfigured to current detection, the unit will only detect On and Off Hook from phones and other telephone equipment placed “behind” the unit. (Telephone equipment has to draw current through the unit in order for the unit to detect that the equipment is Off Hook). Current detection of On and Off Hook requires a series connection as discussed on page 28. Please read “Section II - Telephone Connections” on page 28. For additional information on current detection see Appendix A, page 44.

- 1) Disconnect power to unit
- 2) Remove the four #1 Phillips screws that hold the case together and remove the cover.
- 3) Move each of the 5 jumpers, shown in Fig 8, page 41, such that they connect the center pin of header with the pin closest to the front of the unit.
- 4) Re-assemble unit and connect power.

Fig. 8 Reconfiguring Unit to Current Detection Mode

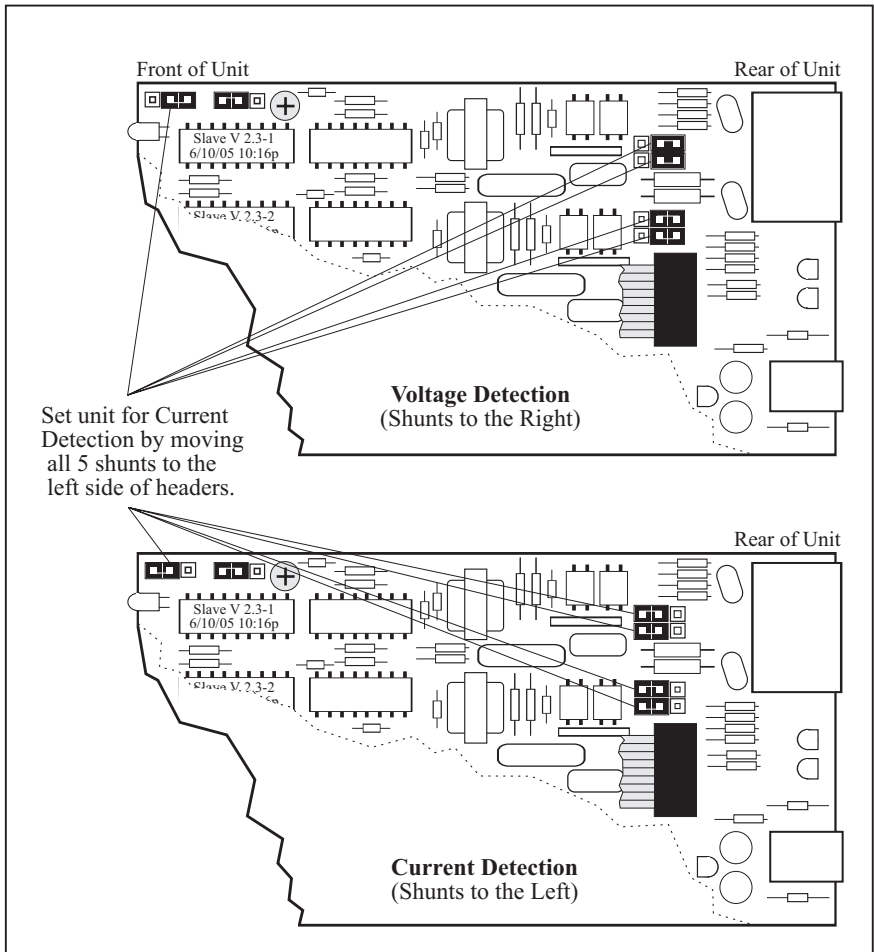

SECTION V
SUPPLEMENTAL INFORMATION

Specifications

Supply Voltage:	9 VDC, center negative
Supply Current:	Less than 250 mA
Loop Current Draw:	Less than 1 mA
Loop Voltage:	30 to 105 VDC
Ringing Voltage:	60 to 130 VAC
Insertion Loss:	Less than 0.3 dB
Voltage Drop:	2.7 VDC at 20 mA loop current
Ringer Equivalence:	(REN) 0.1 B
Dimensions:	1.5" H x 3.35" W x 5.3" L

FCC Information

This unit is designed to conform to federal regulations and complies with Part 68 of the FCC rules. On the back of this equipment is a label that contains the FCC registration number and ringer equivalence number (REN) for this equipment. Upon request, you may have to provide the FCC registration number and the REN to your telephone company.

The ringer equivalence number (REN) is used to determine how many devices can be connected to your telephone line. In most areas, the sum of the RENs on any one line should not exceed 5. If too many devices are attached, your phones may not ring properly and other devices on the line may not detect the ring signal.

In the most unlikely event that your unit causes significant problems on the telephone line, the telephone company can disconnect your service. The telephone company will attempt to notify you in advance and will advise you of your right to file a complaint with the FCC.

The telephone company may make changes in its technical operation and procedures that may affect the operation of this device. The telephone company is required to give adequate notice of such changes. This product should not be connected to coin operated or party line systems.

Manufacture's Information

CallerID.com
3107-D Medlock Bridge Road
Norcross, GA 30071

Sales	(800) 240-4637
Customer Service	(770) 263-7111
FAX	(770) 263-0049
Email	staff@callerid.com
Web Site	www.callerid.com

Warranty Information

CallerID.com will repair this product with new or rebuilt parts, free of charge, when returned shipping prepaid to the CallerID.com repair facility in Norcross, GA within one year from the date of original purchase.

This warranty is extended only to the original purchaser. A purchase receipt or other acceptable proof of purchase date will be required before warranty service is rendered.

This warranty covers failures due only to defects in materials or workmanship occurring during normal use. It does not cover damage which occurs in shipment; failures which are caused by products not manufactured by CallerID.com; failures which result from accident, misuse, abuse, neglect, mishandling, misapplication, alteration, modification or unintended use of product; service by anyone other than an authorized CallerID.com repair facility; or damage attributed to an act of God. Lightning is considered an act of God. CallerID.com makes no other warranty, either expressed or implied, with respect to this product.

If a problem develops concerning this product, contact your local dealer or CallerID.com directly for a Return Material Authorization (RMA) number. A RMA number is required for all returns.

APPENDIX A

VOLTAGE VS. CURRENT DETECTION OF ON AND OFF HOOK

Telephone monitoring equipment can detect the occurrence of the On Hook and Off Hook status of the phone line by two methods. It can either sense the voltage on the phone line itself or sense current flow on a phone line passed through the equipment.

Voltages on phone lines are consistent among all connections and extensions throughout a physical location (building). If the voltage levels are in standard range, monitoring equipment functioning in a voltage detection mode is able to sense On and Off Hook anywhere in the building. The obvious advantage to this detection scheme is that the monitoring equipment can be connected to any extension. Your unit comes from the factory set to voltage detection mode because, in most locations, this detection scheme works properly.

Current on phone lines only flows to the telephone device that is Off Hook. Monitoring equipment that senses On and Off Hook by means of current flow must be connected between the phone company's incoming line and the device(s) that goes Off Hook. The current will flow through the monitoring equipment to the Off Hook device. With this detection scheme, any telephone devices that make or receive phone calls must be attached "behind" the monitoring equipment.

Voltage Detection Circuitry and Telephone Lines

In order to sense the voltage on the phone line, the unit's circuitry must draw a small amount of current from the phone line. The current draw is very small (220 μ A, similar to a voltmeter), and is drawn when the phone line is On Hook. The telephone company's amplifier supplying the power to your location may not be able to supply this current and still keep the On Hook voltage level within the standard range. This occurs primarily in older residential locations. An unsophisticated telephone company repair technician will usually diagnose this small current draw by the unit as a "short" on the line. Therefore, the telephone company will not address the shortcoming of their supply amplifier. If this situation occurs, the unit cannot be used in the voltage detection mode, it must be reconfigured to the current detection mode (see Fig. 8, page 41).

APPENDIX B

EXPLANATION OF START UP SEQUENCE AND FRONT PANEL LIGHTS

Once the unit is powered on, it goes through a start up sequence. The power light comes on, the channel lights are individually pulsed, and the firmware version of the channel microprocessors is sent. This process takes approximately 5 seconds and thereafter, the unit is operational and is ready to monitor calls.

The unit is shipped from the factory set to detect On and Off Hook by sensing the telephone line voltage. Internal jumpers (shunts) can be set to sense On and Off Hook via current flow through the unit. Channel lights will operate differently for voltage and current detect modes

Voltage Detection Mode (Factory Default)

A solid channel light indicates that a live phone line is attached and is On Hook. A channel light that goes out and pulses once every second indicates either an Off Hook condition on that line or a live phone line is not attached

The following discussion assumes a live phone line attached to a channel. When a phone goes Off Hook the channel light goes off and pulses every second. The light will come on during every touch tones dialed. When the phone goes back On Hook the channel light will return to solid on. On inbound calls, the channel light will follow the ring pattern on the line. When the ring signal is present the light will be on. Between rings, the light will go off. Also, when the Caller ID signal is sent between the first and second rings, the light will pulse momentarily

Current Detection Mode (When Internal Jumpers are Reconfigured)

Channel lights will remain on except when a live line is attached and is On Hook. When a live line goes Off Hook the channel light will go off and pulse every second. As with the voltage detection mode, the light will come on during every touch-tone dialed. When the phone goes back On Hook the channel light will return to solid on. On inbound calls, the channel light will follow the ring pattern on the line. When the ring signal is present the light will be on. Between rings, the light will go off. Also, when the Caller ID signal is sent between the first and second rings, the light will pulse momentarily

APPENDIX C

COMMUNICATION PORTS AND INTERRUPTS

Most every device on a PC works in conjunction with the microprocessor by using interrupts. An interrupt stops the microprocessor for a moment to transfer information to or from its data lines. Each device, keyboard, hard drive, floppy drive, communication port, CD ROM, etc. must be assigned a unique interrupt number (IRQ) in order to identify itself to the processor.

Many of these devices have standard IRQ numbers assigned to them. For example, the standard IRQ for a keyboard is 1, the standard IRQ for the floppy drives is 6, the real-time clock is 8, and so on. In the past, the COM ports had standard, and usually fixed IRQ numbers associated with them. But, with the advent of internal fax/modems, CD ROM drives, sound blaster cards, and other add on boards, each needing a unique IRQ, the total number of readily available IRQs have dwindled. IRQs once reserved solely for serial and parallel ports are now being used by add on boards.

Many serial ports now let the user configure the COM port number and interrupt value they need based on their particular hardware arrangement. The COM port number and IRQ value for each serial port is set automatically by the operating system software (plug and play) or by using small connectors on the serial card called jumpers. These jumpers can be moved to change COM port and IRQ settings in accordance with the instructions from board manufacturer.

The primary reason for serial ports not working properly is because they no longer have a unique interrupt value; i.e. they share the same interrupt value with another device. The average PC owner has installed at least one of the previously mentioned add on boards in their system since they have purchased their computer. Each of these boards now use one of the interrupt numbers that may have been originally meant for a serial port. If this is true, the user probably has not noticed any problems, since that particular serial port may not have been in use until now.

In order to make use of this serial port, the system must be configured in order to avoid conflicting interrupt values. The follow table lists the standard default interrupt values for common devices. Your system may vary substantially. Check with your computer consultant for diagnostic programs available that will show the IRQs that your devices are using. The list that follows show some typical IRQ assignments. The assignments on your computer will vary.

IRQ#	Default	Other Common Uses
0	System Timer	Never used by another Device
1	Keyboard	Never used by another Device
2	[Cascade]	Bus Mouse
3	COM 2, COM 4	Internal Fax/Modem
4	COM 1, COM 3	
5	LPT2 (Printer)	Internal Fax/Modem, Network Cards, Potable Hard Drive
6	Floppy Disk	No Other Common Use
7	LPT1 (Printer)	Network Cards
8	Real-Time Clock	Never used by another device
9	Available	Internal Fax/Modem, COM Ports
10	Available	COM Ports
11	Available	Multimedia Cards, Network Cards
12	Available	Bus Mouse, Network Cards
13	Math CoProcessor	No Other Common Use
14	Hard Drive	No Other Common Use
15	Available	Network Cards, Multimedia Cards,

APPENDIX D
RS232 PIN OUTS

9 Pin Connections

When the serial port is configured to “No Flow Control,” only **Transmit**, **Receive**, and **Ground** connections are required. Pin 7 and Pin 8 need to be connected only if other serial flow control types are selected.

Computer DB9/M Serial Port

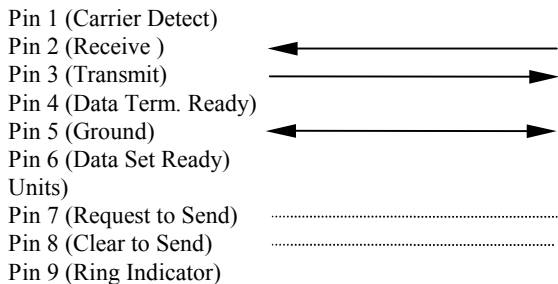

Monitoring Unit DB9/F

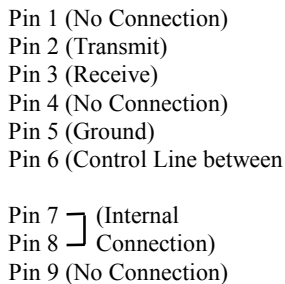

25 Pin Connections

If connecting to a 25 pin serial port on the computer, we suggest using a 9 to 25 pin serial adapter. The pin outs on a 25 pin serial port are not the same as a 9 pin port. When the serial port is configured to “No Flow Control”, only **Transmit**, **Receive**, and **Ground** connections are required. **Request to Send** and **Clear to Send** connections will need to be connected only if other serial flow control types are selected.

Computer DB25/M Serial Port

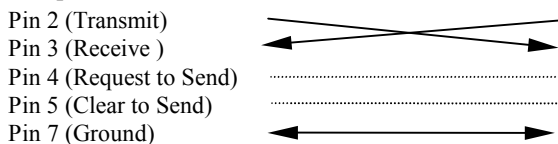

Monitoring Unit DB9/F

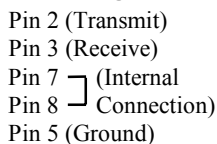



3107-D Medlock Bridge Road, Norcross, GA 30071 800.240.4637 770.263.7111